

SPINNING REEL **8300A**

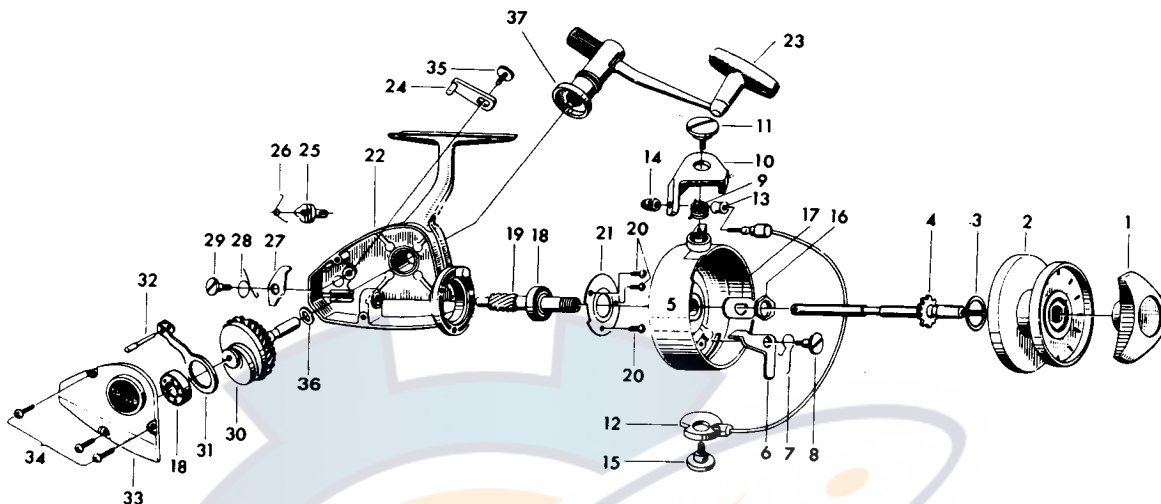

LINE CAPACITY: 200 YDS., 12 LB. TEST (185m. 5.5kg)

Key No.	Parts No.	Parts Name	Price Per Piece	Key No.	Parts No.	Parts Name	Price Per Piece
1	6-000-9021	Drag knob assembly	\$2.45	20	6-351-6501	Ball bearing ret. washer screw	\$ .10
2	6-730-5411	Spool assembly	8.75	21	6-632-3601	Ball bearing ret. washer	.50
3	6-372-5713	Spool washer	.10	22	6-001-2811	Body	7.75
4	6-000-8841	Main shaft assembly	2.70	23	6-745-6611	Handle	4.60
5	6-000-8541	Rotor	5.60	24	6-540-4401	Anti-reverse lever	.50
6	6-570-4401	Bail kick lever	.35	25	6-460-4111	Anti-reverse cam	.35
7	6-140-5031	Bail kick lever spring	.10	26	6-141-7201	Anti-reverse cam spring	.15
8	6-361-2901	Bail kick lever screw	.20	27	6-110-4611	Anti-reverse claw	.20
9	6-141-6621	Bail spring	.10	28	6-141-6521	Anti-reverse claw spring	.10
10	6-230-4821	Arm lever	1.50	29	6-361-3701	Anti-reverse claw screw	.20
11	6-361-3401	Arm lever screw	.60	30	6-000-8721	Drive gear	5.25
12	6-000-8621	Bail	3.40	31	6-480-4101	Oscillating slider	.80
13	6-250-1901	Line roller	.30	32	6-120-7201	Oscillating slider pin	.15
14	6-340-9101	Bail nut	.45	33	6-001-3002	Body cover	5.20
15	6-361-3501	Bail holder screw	.55	34	6-351-6401	Body cover screw	.10
16	6-340-4601	Rotor nut	.20	35	6-350-1931	Anti-reverse lever screw	.10
17	6-372-4901	Rotor retaining washer	.10	36	6-371-2826	Drive gear washer	.10
18	6-631-7611	Ball bearing	3.65	37	6-635-7102	Handle cover	N/A
19	6-401-0042	Pinion	3.40				